



Constellation

Brighton Grammar School, VIC
2023 F1 in Schools World Finals
- 17th Place Overall

2025

Technical Regulations

3DP Class

Version 1.0

Managed by



Re-Engineering Australia
Foundation



Constellation – Brighton Grammar School, VIC – 2023 STEM Racing World Finals - Singapore
(L to R: James Tan, Jenson Galvin, Matt Westerman & James Kitchell)

ENQUIRIES

Re-Engineering Australia Foundation Ltd.
PO Box 136
Castle Hill NSW 1765
P: 61 2 9620 9944
E: contact@rea.org.au
W: www.rea.org.au

COPYRIGHT NOTICE

This document, all its contents (including images, text, procedures) are copyright 2025 Re-Engineering Australia Foundation Ltd. All rights reserved.

- Re-Engineering Australia Foundation Ltd. PO Box 136 Castle Hill NSW 1765 Australia.
- Phone: +61 2 9620 9944. Email: contact@rea.org.au

REA, Re-Engineering Australia, the Re-Engineering Australia Foundation Logo, and other associated logos are trademarks of Re-Engineering Australia Foundation Ltd. All rights reserved

STEM RACING; and the associated logos are trademarks of STEM Racing HQ.

Formula 1®; F1®, Formula 1® and the associated logos are trademarks of Formula 1® Licensing BV.

ACKNOWLEDGEMENT

In preparing the STEM Racing Technical Rules, certain wording and images have been adopted from the World Final Technical Regulations.

REPRODUCTION

This document may only be reproduced by schools registered in the STEM Racing program in Australia regardless of whether they intend to enter teams into the competition. To register your school in the STEM Racing program at no cost, [click here](#). Schools outside of Australia must first seek permission from Re-Engineering Australia Foundation Ltd. prior to reproducing this document.

ALTERATIONS

Re-Engineering Australia Foundation Ltd. reserves the right to alter any specifications and documentation associated with the 'Challenge' without prior notice.

TABLE OF CONTENTS

PREFACE	5
Summary of Main Revisions from Review of 2023/2024 Season.....	5
ARTICLE T1 - DEFINITIONS	6
T1.1 Australian Competition Season.....	6
T1.3 Language Used.....	6
T1.4 Penalties.....	6
T1.5 Competition Classes.....	6
T1.6 F1® in Schools Car.....	7
T1.7 Vertical Reference Plane.....	8
T1.8 Fully Assembled Car.....	8
T1.9 Body.....	8
T1.10 Side Pod.....	8
T1.11 CO2 Cylinder Chamber.....	8
T1.12 Wing.....	8
T1.14 Span.....	8
T1.15 Chord.....	9
T1.16 Thickness.....	9
T1.18 Wheel.....	9
T1.19 Wheel Support System.....	9
T1.22 Tether Line Guide.....	9
T1.23 Surface Finish & Decals.....	9
T1.24 Hand Finishing.....	10
T1.26 Engineering Drawings.....	10
T1.28 Ballast Screws.....	10
ARTICLE T2 - GENERAL PRINCIPLES	10
T2.1 Regulations Documents.....	10
T2.2 Interpretation of the Regulations.....	10
T2.3 Amendments to the Regulations.....	10
T2.4 Safe Construction.....	10
T2.5 Compliance with Critical Regulations.....	10
T2.6 Rectification of Critical Regulation Infringements.....	11
T2.7 Measurements.....	11
ARTICLE T3 - GENERAL CAR REGULATIONS	12
T3.1 Design, Manufacture & Construction.....	12
T3.2 Leading Features Minimum Width.....	12
T3.3 Finishing & Assembly.....	12
T3.4 Car Decals.....	12
T3.5 Undefined Features.....	13
T3.6 Overall Length.....	13
T3.7 Minimum Mass.....	13
T3.9 Default Material.....	13
ARTICLE T5 - BODY & SIDE POD REGULATIONS	14
T5.1 Body Construction.....	14
T5.2 Implants, Foreign Objects or Voids.....	14
T5.3 Width of Side Pod.....	14
T5.4 Side Pod Projected Surface.....	14
T5.5 Virtual Cargo.....	14
ARTICLE T7 - WING REGULATIONS	15
T7.1 Wings.....	15
T7.4 Front Wing Positioning.....	15

T76	Front Wing Construction Material	15
T78	Span.....	15
T79	Span Segments.....	16
T710	Front & Rear Wing Chord	16
T711	Front & Rear Wing Thickness	16
T712	Rear Wing Positioning.....	17
T714	Rear Wing Construction Material	17
ARTICLE T8 - WHEEL REGULATIONS		17
T8.2	REA Standard Wheels	17
T8.8	Visibility in Front View.....	17
T8.9	Visibility from Top, Bottom & Side.....	18
ARTICLE T9 - WHEEL SUPPORT REGULATIONS.....		19
T9.3	REA Standard Grommets.....	19
T9.4	Axles.....	19
T9.5	Modifications.....	19
ARTICLE T10 - TETHER LINE GUIDE REGULATIONS.....		19
T10.1	Location.....	19
T10.2	Separation	19
T10.3	Inside Diameter	19
T10.4	Safety.....	19
ARTICLE T11 - POWER PLANT PROVISIONS.....		20
T11.1	Interfacing with Launch Pod.....	20
T11.2	Diameter.....	20
T11.3	Depth	20
T11.4	Distance from Track Surface.....	20
T11.5	Chamber Wall Thickness.....	20
T11.6	Finishing of Chamber Surrounds.....	20
ARTICLE T12 - APPENDICES		21
T12.1	Official REA Standard Wheel Kit.....	21
T12.2	Example Orthogonal Drawing	22
T12.3	Wing Span Diagram.....	23

PREFACE

This document only contains 'Technical Regulations'. A separate document encompasses the 'Competition Regulations'.

These regulations will be valid for all 2024 State Finals and the 2025 National Final.

Car diagrams and images used in this document are an illustrative representation only and do not necessarily constitute a 'legal' design.

Summary of Main Revisions from Review of 2023/2024 Season

The following summary provides an overview of all technical related regulations that have been revised from the 2023/2024 season's regulations.

It is each team's responsibility to thoroughly read this document in order to identify wording changes and to understand any impact this may have on their project.

All changes between this season and last season are identified within the document by using red underlined text.

ARTICLE T1 - DEFINITIONS

Nil changes

ARTICLE T2 - GENERAL PRINCIPLES

Nil changes

ARTICLE T3 - GENERAL CAR REGULATIONS

Nil changes

ARTICLE T5 - BODY & SIDE POD REGULATIONS

Nil changes

ARTICLE T7 - WING REGULATIONS

Nil changes

ARTICLE T8 - WHEEL REGULATIONS

Nil changes

ARTICLE T9 - WHEEL SUPPORT REGULATIONS

Nil changes

ARTICLE T10 - TETHER LINE GUIDE REGULATIONS

Nil changes

ARTICLE T11 - POWER PLANT PROVISIONS

Nil changes

ARTICLE T1 - DEFINITIONS

T1.1 Australian Competition Season

The standard sequence of Australian competitions runs across two calendar years. The State Finals held Sept/Oct/Nov in one year will feed to the National Final in February/March/April of the following year. There is no pathway for Cadet Class teams to the National Final.

T1.3 Language Used

The language of the regulations is tiered. Those clauses expressed as **"MUST"** or **"WILL"** are mandatory and failure to comply will attract objective penalties - points and/or racing and/or in the extreme, disqualification. Those expressed as **"SHOULD"** or **"MAY"** reflect some level of discretion and choice.

Some clauses will be satisfied through team registration processes or declarations signed as complied with as part of the Challenge Terms and Conditions, whilst others will be tested through a variety of objective and subjective judging.

T1.4 Penalties

A range of penalties will be applied for non-compliance with identified regulations. These penalties include:

T1.4.1 Point Penalty

Invoked from non-compliance with technical regulations and some competition regulations governing portfolio or trade booth restrictions. These are identified as [\[Point Penalty\]](#).



T1.4.2 Time Penalty

Invoked from non-compliance with Technical Regulations which are identified as critical through the use of the danger symbol at left and listed in ARTICLE T2.5. These will be identified as [\[Time Penalty\]](#) and will be applied as 0.02, 0.05 or 0.10 second to every run/lap for every critical regulation violated up to a maximum of 0.5 seconds.

T1.4.3 Eligibility

Teams need to meet certain safety criteria. Failure to comply with certain criteria **MAY** lead to disqualification from racing. [\[Eligibility\]](#).

T1.5 Competition Classes

There are [four](#) competition classes in the Australian STEM Racing competition: [3DP](#), Cadet, Development and Professional.

[This document is only relevant for the 3DP Class ONLY.](#)

[Please note: Due to the 3DP Class regulations being separated from other competition classes and to maintain regulation numbering consistency, some regulations will not appear as sequential. These 'missing' numbers will be present in other competition class regulations.](#)

For more information please refer to the current Australian Competition Regulations [which can be downloaded from the Learning Space on the REA website.](#)

T1.6 F1 in Schools Car

The Car A, also referred to as 'the car', and **MUST** be designed and manufactured according to these regulations for the purpose of participating in races on the STEM Racing track at a State or National Final event, powered only by a single gas cylinder containing 8 grams of pressurised CO₂. STEM Racing cars are designed to travel the 20 metre race distance as quickly as possible, whilst withstanding the forces of launch acceleration, track traversing and physical deceleration after crossing the finishing line.

Each STEM Racing car assembly **MUST** only consist of the following **mandatory** components and/or features:

1. A body
2. Side pods
3. CO₂ cylinder chamber
4. Front wing
5. Rear wing
7. Wheels
8. Wheel support systems
10. Tether line guides
11. Decals

Each STEM Racing car assembly **MAY** include the following optional components and/or features:

12. Surface finishing
13. Ballast screws

Adhesives are permissible for joining components.

Failure to have any of the listed mandatory components or features **WILL** result in all relevant penalties being applied.

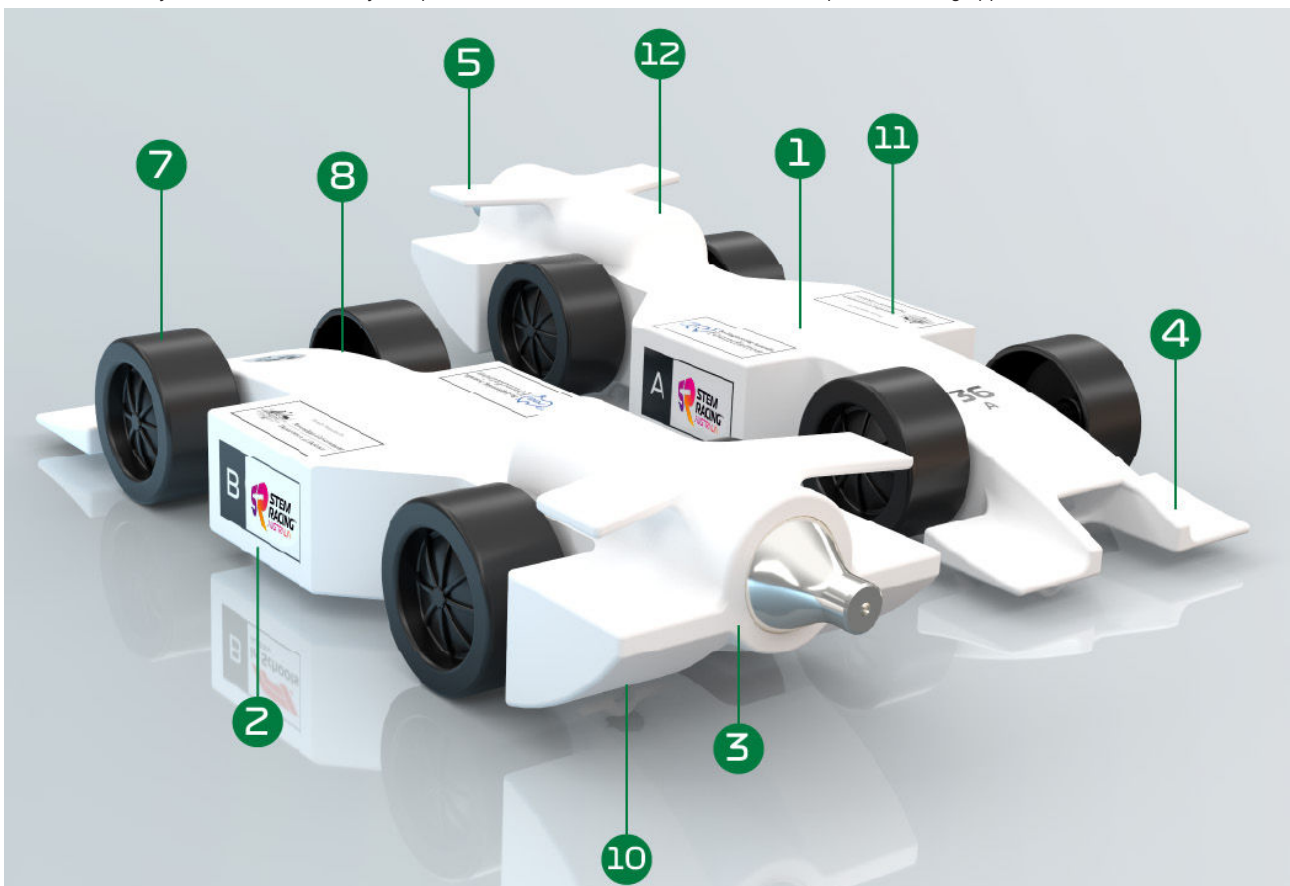

T1.7 Vertical Reference Plane

To assist with describing dimensions, it is assumed that a two dimensional invisible plane exists along the length of the CO2 cylinder chamber centre axis and perpendicular to the track surface. This is known as the vertical reference plane.

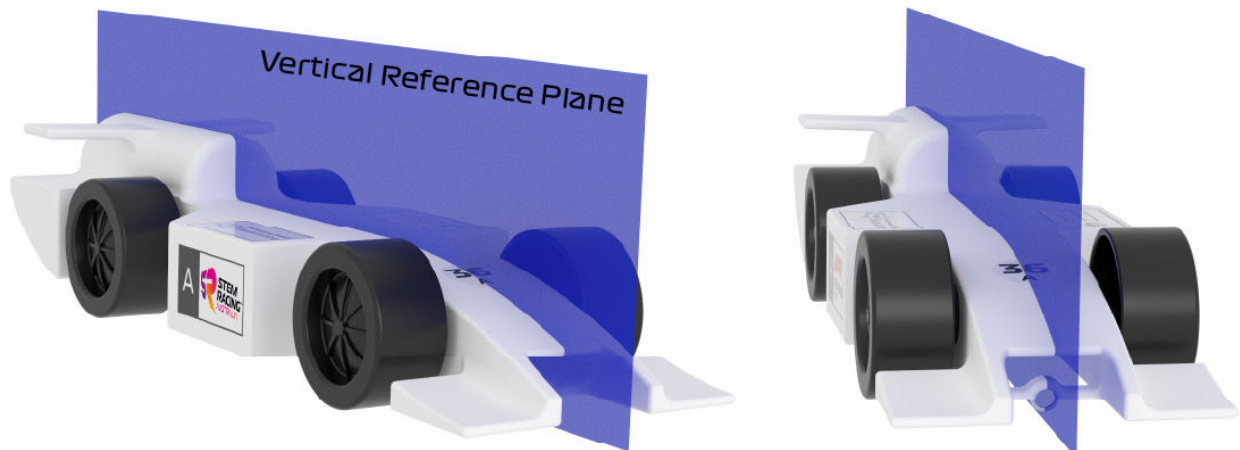

T1.8 Fully Assembled Car

One STEM Racing car, without a CO2 cylinder inserted, presented ready for racing, resting on the track surface, free of any external force other than gravity.

T1.9 Body

The body is defined as the primary connective structure of the car. It is a **solid, uninterrupted** piece of **3D printed plastic** which begins at either the front axle centre line or at the boundary of the front wheel support, and extends rearward. For dimensional purposes the body also includes any attached decals and surface finishes. Any **3D printed plastic** forward of the front axle centre line is not defined as car body. The body can be thought of as the monocoque car chassis with which all other legal components are integrated.

T1.10 Side Pod

Defined as a feature of the car body between the front and rear wheels satisfying the side pod dimensional regulations.

T1.11 CO2 Cylinder Chamber

A circular cylinder of clear space bounded along its side and one end by car body only. This is where the CO2 gas cylinder is placed for racing. Extreme violations of ARTICLE T10 regulations **MAY** lead to cars being deemed ineligible to race due to safety concerns or starting pod incompatibility resulting in zero points for racing.

T1.12 Wing

A wing on an STEM Racing car is an aerodynamic feature that permits airflow around **ALL** of its cross sectional boundary. It includes features of a leading and trailing edge. A wing is dimensionally defined by the minimum dimensions of span and chord, and maximum dimensions of thickness.

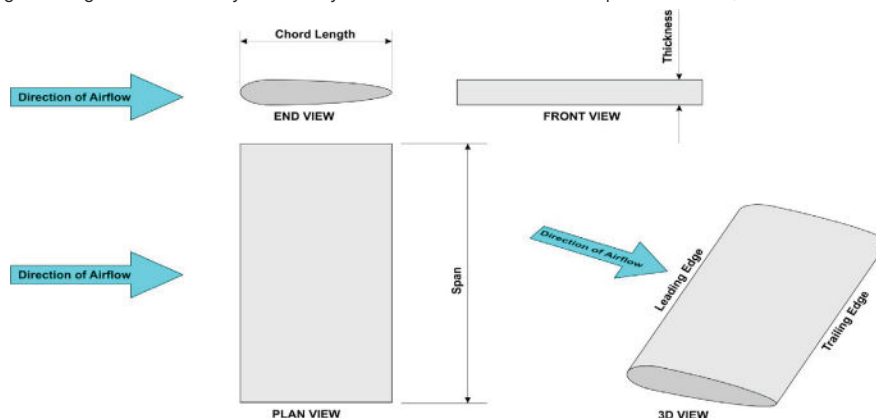

T1.14 Span

Measurement of a wing span is made parallel to the track surface, on the top or bottom surface of the wing (in the 'y' direction), whichever produces the shortest dimension. Intersecting the wing with other car parts including the body, nosecone or supporting structure reduces the

effective span to the sum of the clear airspace envelope segments. An undersized span will lead to deeming the existence of an undersized chord and thickness.

T1.15 Chord

A wing's chord is measured along the chord line from leading edge to trailing edge. Supporting structures are not included in the measurement. The wing chord minimum dimensions **MUST** be satisfied across the minimum dimensions that define the wing span. An undersized chord **WILL** lead to deeming the existence of an undersized thickness.

T1.16 Thickness

The thickness of a wing is measured perpendicular to the chord line. Supporting structures are not included in the measurement. The wing thickness min/max dimensions **MUST** be satisfied across the minimum dimensions that define the wing span.

T1.18 Wheel

A wheel is a single part or assembly of components, cylindrical in form, with its maximum circumference contacting the track surface, enabling motion of the car through its rotation. All material existing within the volume of the extreme diameter and width is considered to be part of the wheel.

T1.19 Wheel Support System

The wheel support system is defined as the grommets and axles that connect the wheels to the car body.

T1.22 Tether Line Guide

A tether line guide is a key safety component which completely surrounds the track tether line so as to safely connect the car to the tether line during races. A tether line guide can be a component sourced from a supplier.

T1.23 Surface Finish & Decals

A surface finish on an STEM Racing car is considered to be any applied visible surface covering, of uniform thickness over the profile of a car component. A decal is material adhered to a component or surface finish. To be defined as a decal, it must be a maximum 2mm in thickness and 100% of the area of the adhering side must be attached to a surface. Surface finishes and decals are included when measuring the dimensions of any components they feature on. Refer to the Competition Regulations for more information.

Teams **MUST** use the **REA supplied** sidepod and corporate logo car sticker decals. These car sticker decals will be provided at the point of event registration and teams will be given 15 minutes to apply them before submitting Cars A for Specifications Judging.

Teams are **NOT** permitted to create their own STEM Racing or REA Corporate Partner car sticker decals.

T1.23.1 F1[®] in Schools Logo Car Sticker Decals

This consists of the 'A F1[®] in Schools decal' for Car A. The F1[®] in Schools logo graphics are printed with a horizontal dimension of 30mm and vertical dimension of 15mm. Teams will be provided with the white **ONLY** background sticker decal. Official car sticker decals are supplied by REA Foundation Ltd at event registration. Refer to the Competition Regulations for more information.

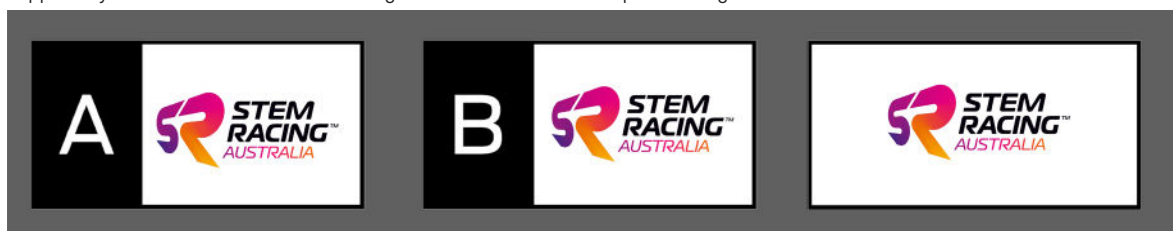

T1.23.2 REA Corporate Partner Car Sticker Decals

This consists of the REA Foundation Ltd logo text and globe graphic, Australian Government Department of Defence logo text and coat of arms graphic, printed with a horizontal dimension of 30mm and vertical dimension of 15mm. Teams will be provided with the white **ONLY** background sticker decal. Official car sticker decals are supplied by REA Foundation Ltd at event registration.

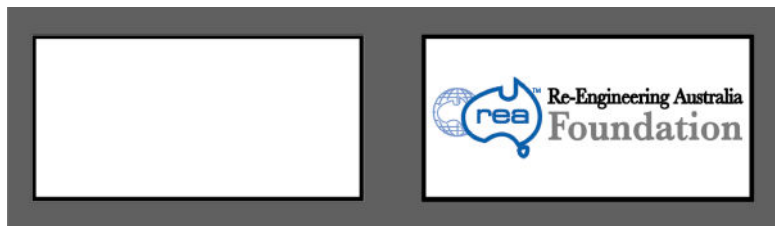

T1.24 Hand Finishing

Hand finishing is defined as use of a hand powered device (e.g. abrasive paper) for removing only the irregularities that may remain on a CNC machined surface of the car body. These irregularities are often referred to as 'scalloping marks'.

T1.26 Engineering Drawings

CAD produced drawings which should be such that, along with relevant CAM programs, could theoretically be used to manufacture the fully assembled car by a third party. Such drawings **SHOULD** include all relevant dimensions, tolerances and material information. STEM Racing engineering drawings **MUST** include detail to specifically identify and prove compliance for the virtual cargo and wing surfaces.

T1.28 Ballast Screws

Metal screws are permissible for mass ballast, these are only to be used to ballast the car up to the minimum weight.

ARTICLE T2 - GENERAL PRINCIPLES

T2.1 Regulations Documents

REA Foundation Ltd. issues the regulations, their revisions and amendments made.

T2.1.1 Technical Regulations

This document. The Technical Regulations document is mainly concerned with those regulations that are directly related to STEM Racing car design and manufacture. Technical Regulation article numbers have a 'T' prefix.

T2.1.2 Competition Regulations

A document separate to this one which is mainly concerned with regulations and procedures directly related to judging and the competition event. Competition Regulation article numbers have a 'C' prefix.

T2.2 Interpretation of the Regulations

The final text of these regulations is in English should any dispute arise over their interpretation. The text of a regulation, diagrams and any related definitions should be considered together for the purpose of interpretation.

Text Clarification - Any questions received that are deemed by REA Foundation Ltd. to be related to regulation text needing clarification will be answered by REA Foundation Ltd.

T2.3 Amendments to the Regulations

Any amendments will be announced and released by REA Foundation Ltd. by email notification to all teachers nominated in the school registration, as well as the updated revision being uploaded to the website at <http://rea.org.au/f1-in-schools/>. Any amended text will be indicated thus (using red underlined text).

T2.4 Safe Construction

[Eligibility | 10 Pt Penalty]

All submitted cars will be inspected closely to ensure that they are engineered and constructed safely for the purpose of racing. High importance is placed on ensuring that tether line guides are robust and secure. If the Judges rule any aspect of a team's race cars to be unsafe for racing, the team will be required to make repairs / modifications. Any such repair work **WILL** result in a penalty being applied. Teams are advised to check both the Technical and Competition Regulations for further advice.

T2.5 Compliance with Critical Regulations

Points are deducted for non-compliance with the technical regulations. Car A is scrutinised and points will be deducted for any infringements. These penalties are only imposed once, per infringement

T2.5.1 Penalties for Critical Regulations

Some of the more critical regulations **WILL** attract both a Point Penalty and Time Penalty as per ARTICLE T1.4. The critical regulations are:

Penalty = 4 Pts and 0.05s Time Penalty

T3.5 / T5.1 / T5.2 / T8.2 / T8.2.1 / T8.7 / T9.3 / T11.7

Penalty = 4 Pts and 0.02s or 0.05s Tiered Time Penalty

T3.6 / T5.5 / T7.8.1 / T7.8.2 / T8.8 / T8.9 / T11.4

Penalty = 20 Pts and 0.1s Time Penalty

T7.1.1 / T7.1.2

T2.5.2 Tiered Time Penalties

Dimensional critical regulations will be measured and violations less than 1mm will attract a time penalty of 0.02 seconds. Violations of 1mm or more will attract a time penalty of 0.05 seconds.

T2.6 Rectification of Critical Regulation Infringements

Teams whose race cars have been deemed by Scrutineers to have infringed a regulation attracting a Time Penalty, **MAY** be given an opportunity to rectify this (time permitting) prior to racing with the effect of removing the time penalty. The original point penalty will stand. Teams unable to rectify at this time should refer to the Competition Regulations for more information.

T2.7 Measurements

T2.7.1 No Tolerance Unless Stated

No tolerance will be applied for dimensions unless otherwise stated.

T2.7.2 No Tolerance for Mass

No tolerance will be applied when measuring mass.

T2.7.3 Dimensional Measures

All car component dimensions are inclusive of any applied paint finish or decal. A series of specially manufactured gauges will be used to broadly verify dimensional compliance. Accurate measuring tools, such as Vernier calipers, will then be used to closely inspect any dimensions found to be close to the dimensional limits per the initial gauge inspection.

T2.7.4 Scrutineering of Finished Product

Whilst your CAD design **MAY** comply with dimensional regulations, the process of machining, finishing and assembly **WILL** individually impact on the final dimensions of the finished product submitted for scrutineering. It is the actual product that is measured in scrutineering. It is not the design intent that is judged in scrutineering.

T2.7.5 Mass Measurements

All mass measurements will be made using the REA Foundation Ltd. electronic competition scales which are accurately calibrated to +/- 0.1g.

T2.7.6 Scrutineering with CO2 Cylinder Inserted

Scrutineering of cars will be conducted with a charged CO2 cylinder inserted into the chamber. The mass of the cylinder will be 29g with a tolerance of +/- 0.5g.

T2.7.7 Scrutineering Throughout all Configurations

Scrutineering of cars will be conducted by examining cars throughout all possible configurations. Refer to ARTICLE T1.20.

ARTICLE T3 - GENERAL CAR REGULATIONS

T3.1 Design, Manufacture & Construction

[Eligibility | 10 Pt Penalty]

T3.1.1 CAD & CAM Software Required

All STEM Racing cars **MUST** be designed and engineered using CAD (Computer Aided Design) and CAM (Computer Aided Manufacture) technology. CAD software used should provide for 3D part modelling, assembly and 3D realistic rendering. The CAM package should allow students to simulate the **3D printing** processes so they can show evidence of these in their portfolio. We recommend the use of DENFORD QuickCAM PRO software.

T3.1.2 CNC Requirement

All non-rotation parts of the car **MUST** be manufactured via material addition using a 3D Printing machine.

T3.1.7 No Separately Formed Parts

No 3D printed parts are to be separately formed and glued to the main body.

T3.2 Leading Features Minimum Width

[Eligibility | 10 Pt Penalty]

The minimum width of any pointed feature of the car assembly **MAY** vary over the first 6mm of its length from its forward most extremity. Teams are advised to check ARTICLE T2.4 for further advice.

T3.2.1 Forward Most Extremity

Minimum width at forward most extremity: 3mm or R1.5mm

T3.2.2 6mm Back from Forward Most Extremity

Minimum width at 6mm back from forward most extremity: 6mm

T3.3 Finishing & Assembly

T3.3.1 Post Machining Processes

[Advice]

All cars are expected to be finished to a high standard and **MUST** reflect the features of the documented CAD design. Features of the machined car other than machining scallops **SHOULD NOT** be removed.

T3.3.3 Hand Finishing

[10 Pt Penalty]

Hand finishing of the car assembly is permitted. Maximum variation to CAD model - including Critical Regulation Rectification processes - is 3mm.

T3.3.4 Hand Created Features

[10 Pt Penalty]

No feature of the car body, side pods and wings is to be created solely by a hand process.

T3.4 Car Decals

T3.4.1 Team Number Decals

[2 Pt Penalty]

Each team will receive a unique Team Number and a corresponding Team Number Decal, which includes the Team Number followed by an "A". This decal is required to be affixed to the race car's body, positioned specifically between the leading edge of the Virtual Cargo and the leading edge of the front tires. The decal **MUST** be clearly visible in the plan view. While teams have the option to create and apply their own Team Number Decals to their vehicles before the event, decals will also be made available at the time of event registration for those who need them.

Decal Diameter: 15.0mm

Decal Font: Formula 1 Font

Font Weight for Number: 18pt

Font Weight for A: 9pt



T3.4.2 REA Foundation Ltd. Corporate Partner Logos

[2 Pt Penalty each]

These sticker decals **MUST** be displayed on all cars at State and National Finals and will be supplied by REA at event check-in. Refer to T1.23 for more information. Each decal infringement attracts a 2pt penalty.

T3.4.3 Minimum Dimensions & Positioning

T3.4.3.1 Minimum Dimensions

The REA Foundation Ltd., Department of Defence and STEM Racing sticker decals **MUST** maintain minimum dimensions of 30mm long and 15mm wide. Any trimming of decals will result in a 2pt penalty for each infringement.

T3.4.3.2 Positioning of 'A' in Schools Sticker Decals

[2 Pt Penalty each]

The 'A' STEM Racing decals are to be applied to the Car's sidepods. Refer to ARTICLE T1.22.1. Each decal infringement attracts a 2pt penalty. Picture following example only.



T3.4.3.3 Positioning of Other Corporate Sticker Decals

[2 Pt Penalty each]

All remaining REA supplied corporate sticker decals **MUST** be clearly visible in the top or side view of the car.

T3.4.4 Regional Sponsors

[Advice]

If your region is supported by a sponsor, corresponding sponsor recognition **MUST** be included in displays, portfolio and on the car.

T3.5 Undefined Features

[0.05 Time Penalty] [4 Pt Penalty]

 The car assembly **MUST** only consist of components listed in ARTICLE T1.6.

T3.6 Overall Length

[0.02 or 0.05 Time Penalty] [4 Pt Penalty]

 The overall length of the complete car measured between the front and rear extremes of the car product, including all components with the exception of the CO2 cylinder, **MUST** be a minimum of 170mm and a maximum of 210mm.

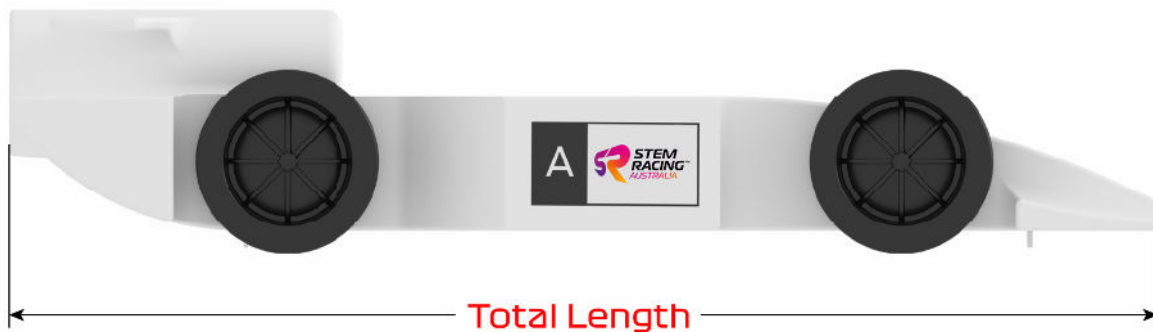

T3.7 Minimum Mass

[Eligibility]

The minimum mass of the complete car product, without the CO2 cylinder fitted **MUST** be:

T3.7.1 3D Printed Class: 55 grams

T3.9 Default Material

T3.9.1 3DP Class

[0.05 Time Penalty] [4 Pt Penalty]

 3D Printed Plastic is the default material for all non-rotating components of the car including the body and side pods. Other materials can only be used as explicitly specified.

T3.9.2 Thickness

[1 Pt Penalty]

3D Printed components **MUST** be a minimum of 3mm thick.

ARTICLE T5 - BODY & SIDE POD REGULATIONS

T5.1 Body Construction [0.05 Time Penalty] [4 Pt Penalty]

T5.1.1 3D Printed Class Body Construction

A single, continuous piece of 3D printed plastic, deemed the body, **MUST** exist rear of the front axle centre line. The body begins at either the front axle centre line or at the boundary of the front wheel support and extends rearward. The body, encompasses the side pods, virtual cargo and CO2 cylinder chamber.

T5.2 Implants, Foreign Objects or Voids [0.05 Time Penalty] [4 Pt Penalty]

Implants, foreign objects or voids in or on the car body and side pods **MUST NOT** be incorporated.

T5.3 Width of Side Pod [2 Pt Penalty]

The overall width of the side pods measured transversely between the side-pod extremities **MUST** be a minimum of 40mm. Any part having a width less than 40mm is not considered a side pod.

T5.4 Side Pod Projected Surface [2 Pt Penalty]

Each side pod **MUST** present a complete rectangular projected surface when viewed from the side measuring not less than 30mm wide x 15mm high.

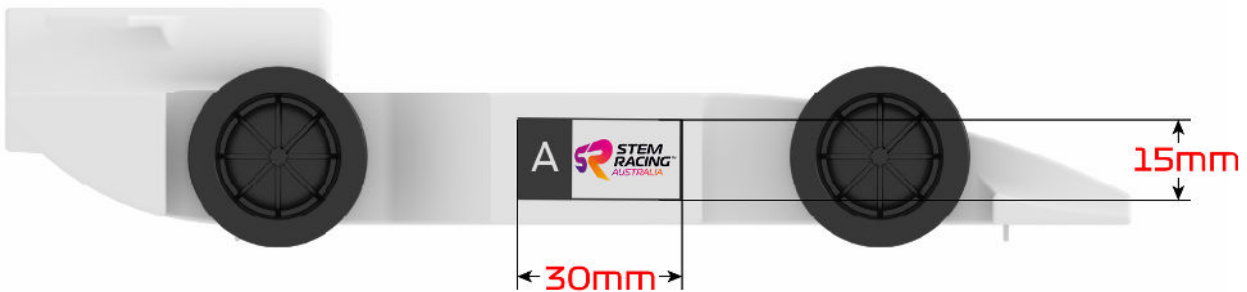

T5.5 Virtual Cargo [0.02 or 0.05 Time Penalty] [4 Pt Penalty]

A virtual cargo **MUST** be completely encompassed by the body and be wholly positioned between the front and rear wheel centre lines. The virtual cargo **MUST** have minimum dimensions as shown below, with its top surface split symmetrical by the vertical reference plane of the car body. The virtual cargo **MUST NOT** be intersected by the FRONT wheel support system but **MAY** share common faces with the car body

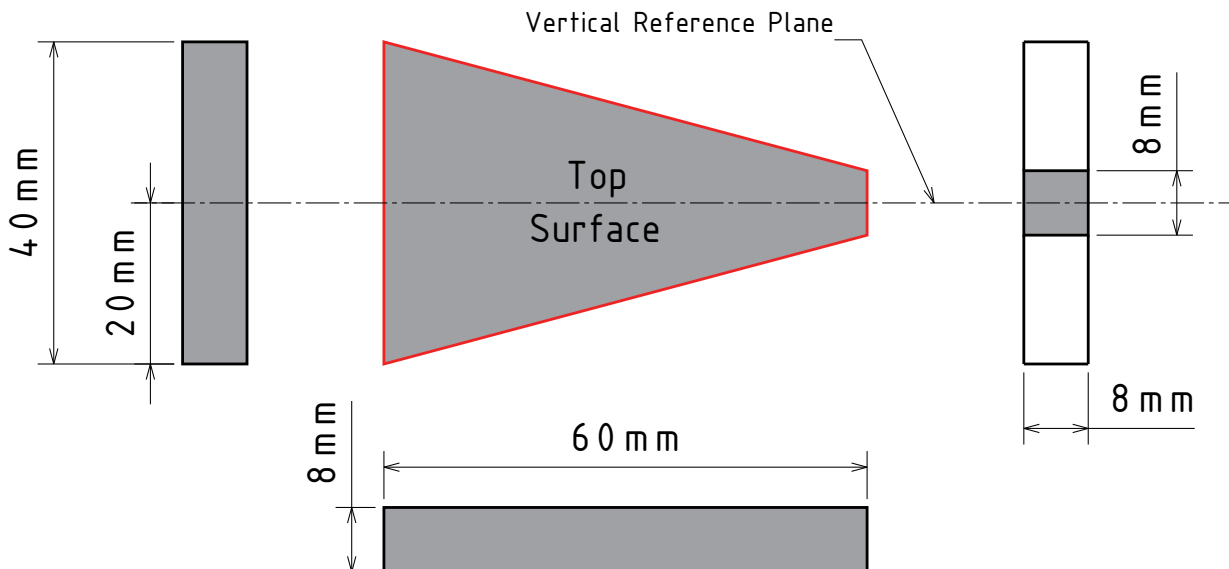

ARTICLE T7 - WING REGULATIONS

T7.1 Wings



T7.1.1 Car has a Front Wing

[0.10 Time Penalty ☒20 Pt Penalty]

Car must have a Front Wing. If the car fails this regulation then skip without penalties all subsequent T7 Front Wing Regulations.



T7.1.2 Car has a Rear Wing

[0.10 Time Penalty ☒20 Pt Penalty]

Car must have a Rear Wing. If the car fails this regulation then skip without penalties all subsequent T7 Rear Wing Regulations.

T7.4 Front Wing Positioning

[1 Pt Penalty]

The whole of the front wing and support structure when viewed from the side **MUST** be in front of the centre line of the front axle.

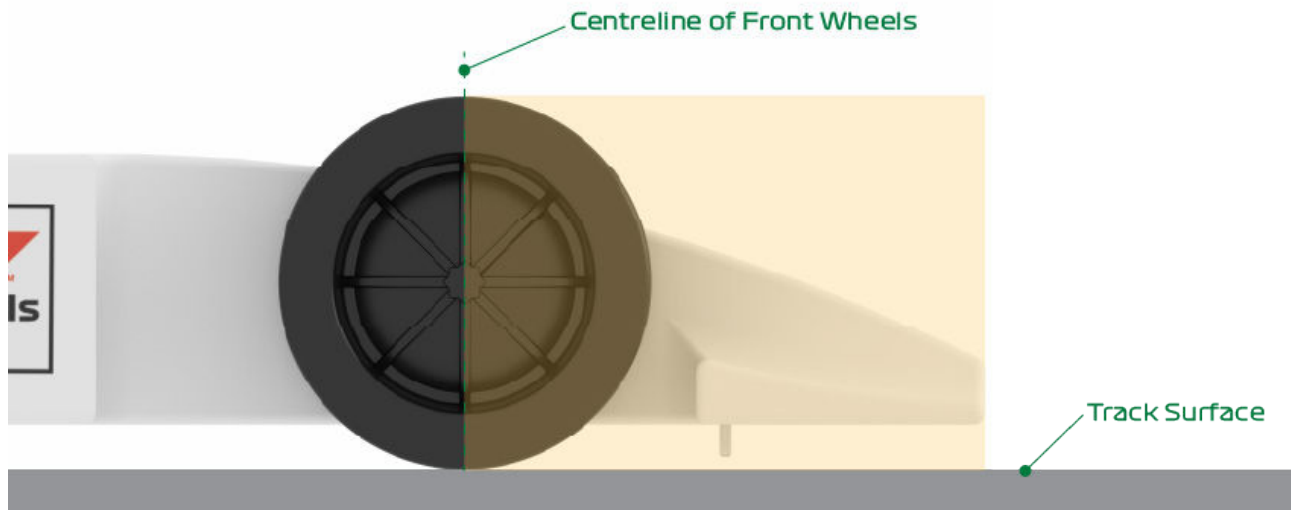

T7.6 Front Wing Construction Material

[0.05 Time Penalty | 4 Pt Penalty]

Teams **MUST** manufacture the front wing from 3D printed plastic.

T7.8 Span

Where the wing span is intersected by another part of the car, the total span is the sum of each segment. The wing span is measured on the top or bottom surface of the wing, whichever is shortest, parallel to track surface and normal to the vertical reference plane. Refer to T11.7 for a number of examples.



T7.8.1 Front wing span

[0.02 or 0.05 Time Penalty ☒4 Pt Penalty]

T7.8.1.1 Min: 34mm



T7.8.2 Rear wing span

[0.02 or 0.05 Time Penalty ☒4 Pt Penalty]

T7.8.2.1 Min: 34mm

T7.9 Span Segments

The span of a wing can be intersected by the car body, nosecone or wing support structure to form span segments. All span segments **MUST** conform to the wing chord and thickness regulations. If intersected, at least two (2) of the front wing segments and two (2) of the rear wing segments must be no less than the minimum size in span.

Minimum segment span: 10mm

Wing and Span Calculations Explained

To be included in the judge's wing span calculation, a wing segment **MUST** be at least 10mm in span. If **ANY** of the segments A, B, C, D were less than 10mm, they would not qualify as wing segments, but would instead be treated as wing support structures.

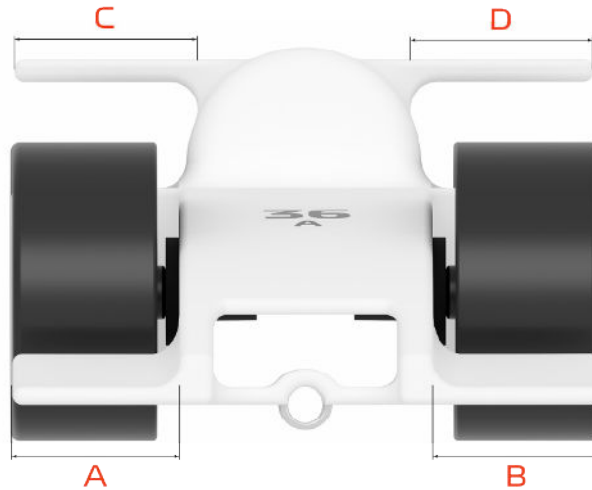

T7.10 Front & Rear Wing Chord

The wing chord requirements **MUST** be satisfied throughout the wing's minimum span. The chord is the distance between the leading edge and trailing edge measured parallel to the vertical reference plane. Each individual element of a multi-element wing **MUST** satisfy the minimum chord requirement.

T7.10.1 Front wing chord - Min: 15mm

[2 Pt Penalty]

T7.10.2 Rear wing chord - Min: 15mm

[2 Pt Penalty]

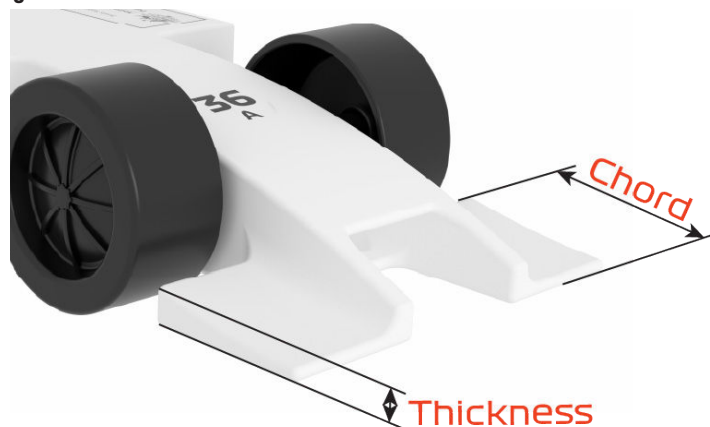

T7.11 Front & Rear Wing Thickness

The wing thickness requirements **MUST** be satisfied throughout the wing's minimum span, measured perpendicular to the chord line.

T7.11.1 Front wing thickness

[2 Pt Penalty]

T7.11.1.1 Min: 3.5mm / Max: 9mm

T7.11.2 Rear wing thickness

[2 Pt Penalty]

T7.11.2.1 Min: 3.5mm / Max: 9mm

T7.12 Rear Wing Positioning

The whole of the rear wing when viewed from the side **MUST** be behind the centre line of the rear axle, track surface.

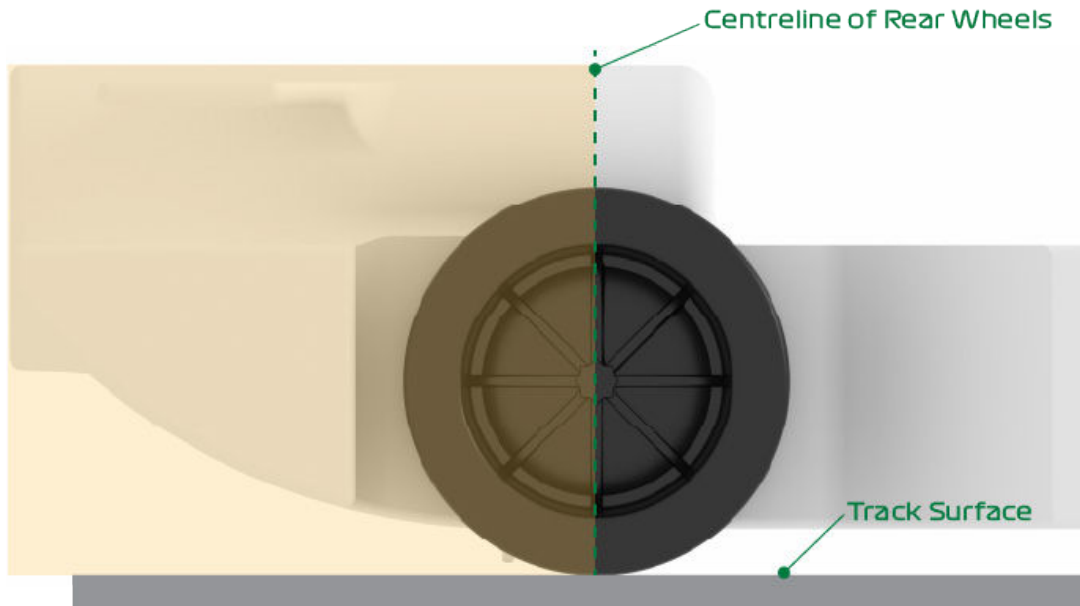

 **T7.14 Rear Wing Construction Material** [0.05 Time Penalty] [4 Pt Penalty]
 Teams **MUST** manufacture the rear wing and any supporting structure from 3D printed plastic.

ARTICLE T8 - WHEEL REGULATIONS

 **T8.2 REA Standard Wheels** [0.05 Time Penalty] [4 Pt Penalty]
 Teams **MUST** use any combination of four (4) unmodified REA standard wheels. No other parts can be added to the wheels. Removal of the sprue remnant is acceptable.

 **T8.8 Visibility in Front View** [0.02 or 0.05 Time Penalty] [4 Pt Penalty]
 Visibility of the front wheels in the car's front view **MUST** only be obstructed to a height of 15mm from the track surface.



T8.9 Visibility from Top, Bottom & Side [0.02 or 0.05 Time Penalty 4 Pt Penalty]

The visibility of all wheels must not be physically obscured by any component of the car in the car's top and bottom elevation views. Car body or any other components must not exist within the dimensions illustrated below. These dimensions must exist from the inside edges of each wheels' track contact width to the extreme width of the car assembly and a height from track surface of 65.0mm. This is measured, parallel to the vertical reference plane and track surface.

T8.9.1 In front of front wheels

Min: 1.0mm

T8.9.2 Behind front wheels

Min: 15.0mm

T8.9.3 In front of rear wheels

Minimum dimensions on diagram below

T8.9.4 Behind rear wheels

Min: 1.0mm

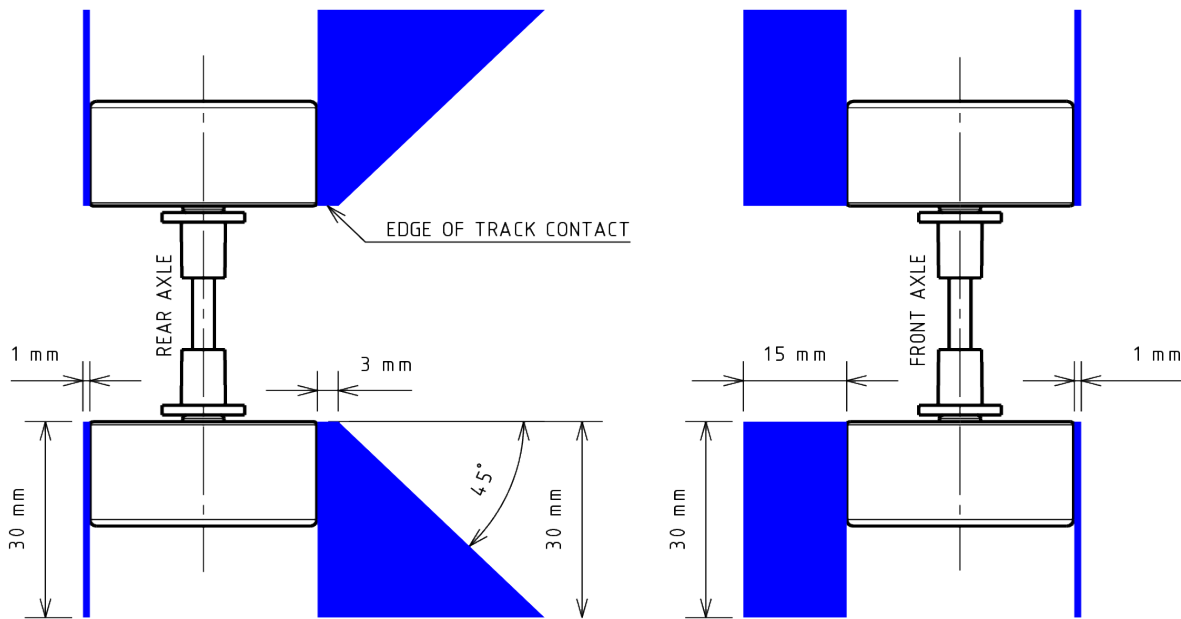

ARTICLE T9 - WHEEL SUPPORT REGULATIONS

T9.3 REA Standard Grommets [0.05 Time Penalty] [4 Pt Penalty]

Teams **MUST** use four (4) unmodified REA axle grommets.

T9.4 Axles [2 Pt Penalty]

Teams **MUST** use REA standard brass axles (3.175mm) **OR** axles from a different material with a minimum 3mm diameter.

T9.5 Modifications [2 Pt Penalty]

Teams **MUST NOT** use any other parts or make any other modifications to the wheel support system.

ARTICLE T10 - TETHER LINE GUIDE REGULATIONS

T10.1 Location [Eligibility] [10 Pt Penalty]

Each car **MUST** have 2 (essentially circular) tether line guides firmly secured toward the front and rear of the car, located on the underside along the car body centre line. The track tether line passes through these two tether line guides. An adhesive **MAY** be used to help secure the tether line guides.

T10.2 Separation [1 Pt Penalty]

The longitudinal separation of the tether line guides as measured between the inside edges of the guides **MUST** be a minimum of 120mm.

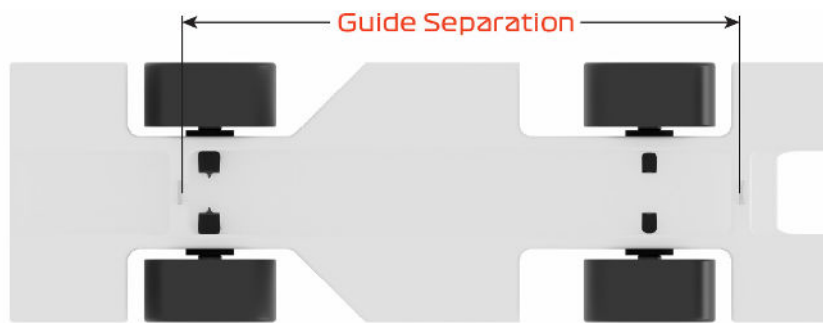

T10.3 Inside Diameter [2 Pt Penalty]

The inside diameter of the tether line guide (referring to the size of the hole) **MUST** be a minimum of 3mm

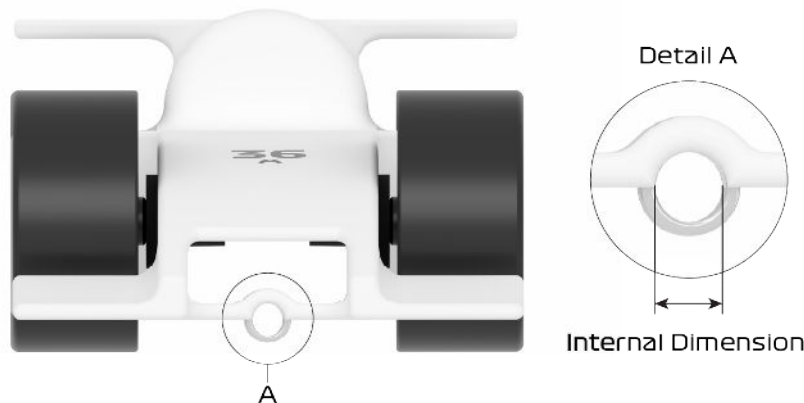

T10.4 Safety

T10.4.1 Closed Guides [Eligibility] [4 Pt Penalty]

The tether line guides **MUST** be closed to prevent the tether line from coming out of the tether line guide. This is considered a safety issue. Cars **WILL** be ineligible to race if unresolved.

T10.4.2 Sharp Edges [Eligibility] [4 Pt Penalty]

Tether guide arrangements with sharp edges **WILL** be prevented from racing.

T10.4.3 Strength & Fixing

Adequate strength and fixing of the tether line guides **MUST** be considered a safety issue and cars with unsafe arrangements will be ineligible to race if unresolved. The guides must be robust so as to prevent the diameter or shape changing during racing. A tether line guide test will be conducted during scrutineering using a 200g mass (2.0N max) to check the guides are securely fitted to the car and safe to race.



ARTICLE T11 - POWER PLANT PROVISIONS

T11.1 Interfacing with Launch Pod

[Eligibility 20 Pt Penalty]

The cylinders provide the car propulsion and when fully inserted, all cars **MUST** interface directly with the standard track starting pod mechanism without the use of additional launch equipment.

T11.2 Diameter

[1 Pt Penalty]

The CO2 cylinder chamber diameter **MUST** be 19mm (+/- 0.5mm)

T11.3 Depth

[1 Pt Penalty]

Depth of chamber measured parallel to the vertical reference plane anywhere around the chamber circumference from opening to chamber end **MUST** be a minimum 45mm and maximum 60mm.

 **T11.4 Distance from Track Surface** [0.02 or 0.05 Time Penalty 4 Pt Penalty]

The vertical height of the lowest point of the CO2 cylinder chamber above the race track surface **MUST** be a minimum of 22mm for the 3DP Class.

T11.5 Chamber Wall Thickness

[Eligibility 4 Pt Penalty]

The CO2 cylinder chamber **MUST** be completely surrounded by a minimum 3mm thickness of material. The chamber surrounds and connection to the car body will be assessed and if determined below the minimum thickness, may be considered a safety issue at the judge's discretion. Minimum thickness is measured through any line of the chamber radius. **IMPORTANT:** The entire circumference and length of the cylinder chamber must not be punctured by any object.

Min: 3mm

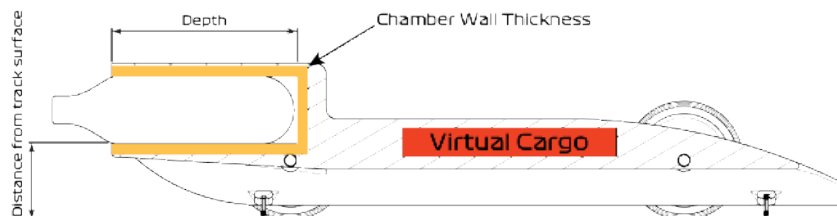

T11.6 Finishing of Chamber Surrounds

[1 Pt Penalty]

Paint and other foreign materials **MUST NOT** be present inside the CO2 cylinder chamber. This is considered a measure of manufacturing quality control.

ARTICLE T12 - APPENDICES

T12.1 Official REA Standard Wheel Kit

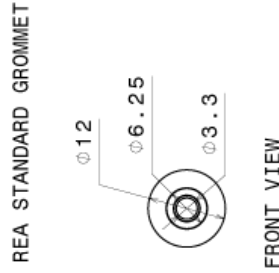
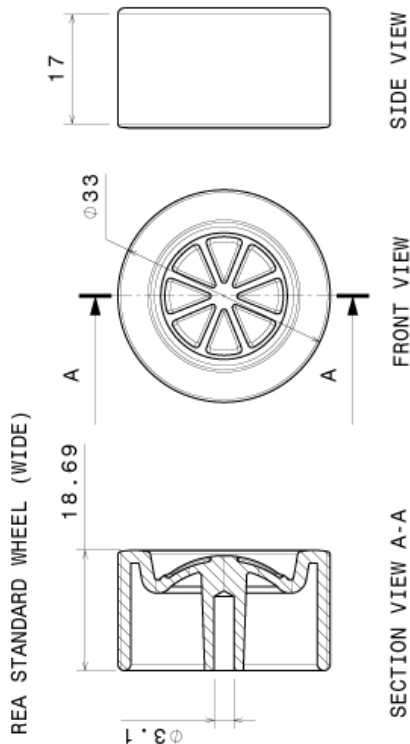
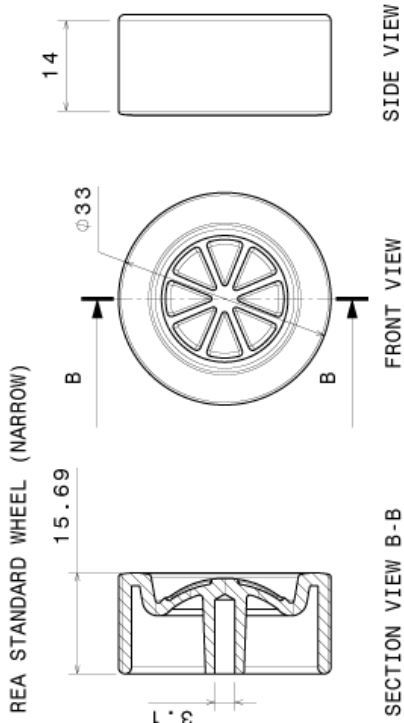

REA STANDARD TETHER GUIDE

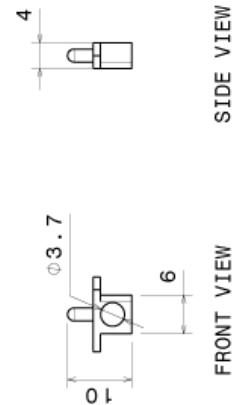

ALL MEASUREMENTS ARE IN (MM) UNLESS OTHERWISE STATED

REVISIONS:		REA STANDARD WHEEL KIT	
DATE:	20/05/2015	Re-Engineering Australia Foundation	
CHECKED BY:	W. SMITH	REVISION NUMBER	1/1
DATE:	20/05/2015	DRAWING NUMBER	
SIZE:	A4	REA - WK	SHEET
SCALE:	NB 0.00	1/1	

This drawing is our property. It can't be reproduced or commercialised without our written agreement.

T12.2 Example Orthogonal Drawing

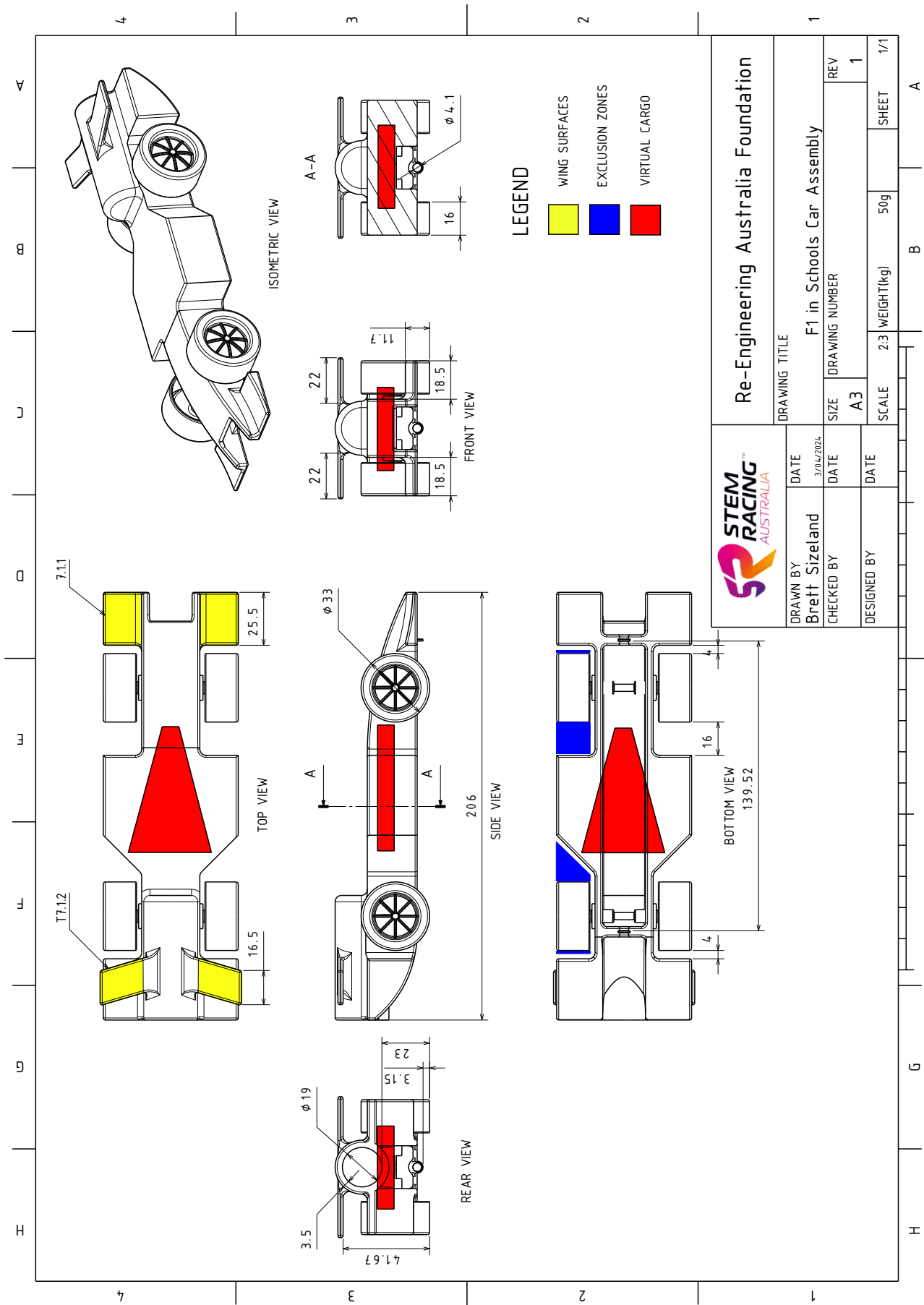

T12.3 Wing Span Diagram

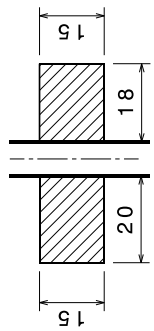

SPAN: 20+18=38
 PASS: Balsa
 FAIL: Alternative

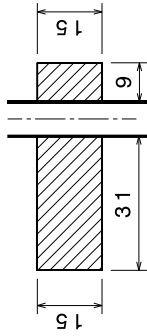

SPAN: 31+0=31
 FAIL: Balsa
 FAIL: Alternative

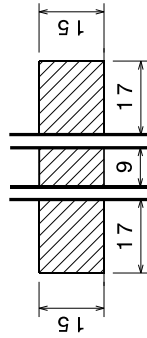

SPAN: 17+0+17=34
 PASS: Balsa
 FAIL: Alternative

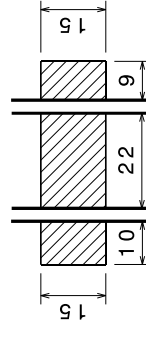

SPAN: 10+22+0=32
 FAIL: Balsa
 FAIL: Alternative

SCRUTINEERING PRINCIPLES:

- THE SPAN OF A SEGMENT MUST BE AT LEAST 10 mm TO BE INCLUDED IN WING SPAN CALCULATION (RULES T6.8)
- CHORD (T6.9), THICKNESS (T6.10) AND CLEAR AIRSPACE RULES (T6.2) APPLY OVER EACH VALID WING SEGMENT

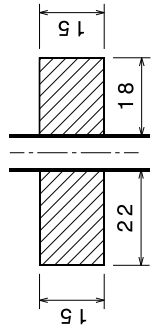

SPAN: 22+18=40
 PASS: Balsa
 PASS: Alternative

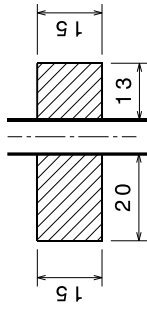

SPAN: 20+13=33
 FAIL: Balsa
 FAIL: Alternative

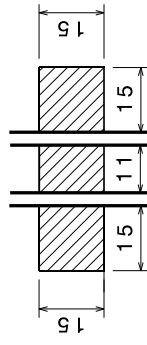

SPAN: 15+11+15=41
 PASS: Balsa
 PASS: Alternative

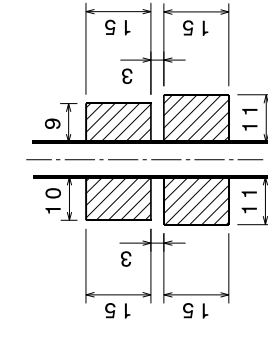

SPAN: 11+10+11+0=32
 FAIL: Balsa
 FAIL: Alternative

WING SEGMENTS

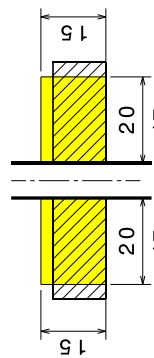

PASS: Span
 FAIL: Chord+Thickness

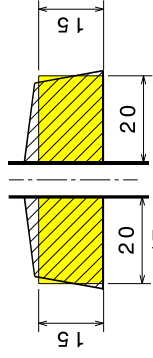

PASS: Span
 FAIL: Chord+Thickness

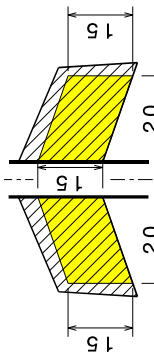

PASS

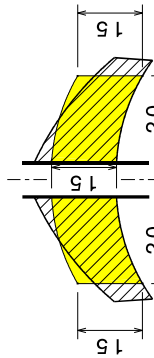

PASS: Span
 FAIL: Chord+Thickness

SCRUTINEERING PRINCIPLES:

- ACTUAL WING PROFILE (CROSS-HATCHED) MUST TOTALLY ENCLOSE THE MINIMUM SPAN AND CHORD AREA (YELLOW) (RULES T6.7 AND T6.9)
- THICKNESS RULE (T6.10) AND CLEAR AIRSPACE RULE (T6.2) APPLY OVER ENTIRE ACTUAL WING PROFILE (CROSS-HATCHED)

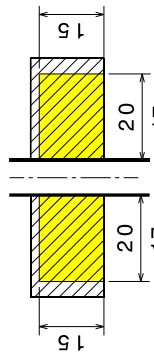

PASS

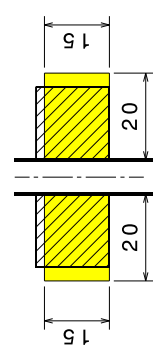

FAIL: Span+Chord+Thickness

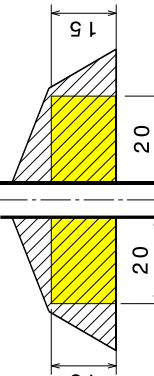

PASS

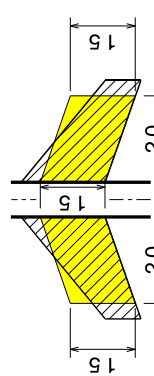

PASS: Span
 FAIL: Chord+Thickness

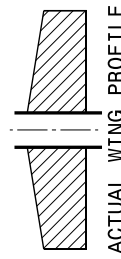

ACTUAL WING PROFILE

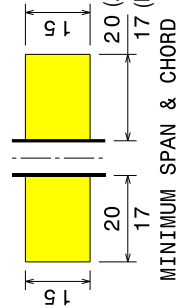

MINIMUM SPAN & CHORD

2-PIECE SYMMETRICAL WING



RE-ENGINEERING AUSTRALIA FOUNDATION

**ENGAGE
INSPIRE
EDUCATE
STUDENTS
TEACHERS
INDUSTRY**